

Nakajima Template of Lower Arch Analysis

Eiichiro Nakajima*, Tadashi Watanabe and Harry K Okamoto

Private Practice, Tokyo, Japan

*Corresponding Author: Eiichiro Nakajima, Private Practice, Tokyo, Japan.

Received: January 30, 2018; Published: April 13, 2018

Abstract

There are many kinds of templates for a lateral head plate.

However, we have not yet seen a template for a horizontal flat plane, although we observe them in every day practice as an arch form.

There are four main parts in our newly developed template.

- 1) The Semicircle Outline : the operator can use this for a very wide range, from -2.0SD to +1.5SD of Σ lower: 5 - 5 or Σ upper: 5 - 5 (mesio-distal width). One does not have to calculate a radius each time. All one has to do is to calculate the sum of the widths of lower: 5 - 5.
- 2) The cross-sectional outline of the teeth and brackets one can get an actual image of the arch form for the treatment.
- 3) L1 to APO H (lower incisor to APO Horizontal). Indicator – One can readily locate and draw the midline and also draw L1 to APO H line.
- 4) Built – in Calculator

One does not have to look for the calculator any longer.

One of the main purposes of this template is to actually visualize the arch length analysis. Moreover one can combine the lower arch VTO with the lateral VTO to achieve a more three dimensional image than was possible previously. Also one can superimpose both the pre- and post- treatment results as well as the VTO and the posttreatment results, in order to obtain feedback for one's future treatments.

Keywords: Nakajima Template; Lower Arch

Introduction

There are many kinds of templates for a lateral head plate. However, we have not yet seen a template for a horizontal flat plane, although we observe them in everyday practice as an arch form.

One of the main purposes of this template is to actually visualize the arch length analysis. Moreover, one can combine the lower arch VTO to achieve a more three dimensional image than was possible previously. In addition one can superimpose both the pre-and post-treatment results as well as the VTO and the post treatment results, in order to obtain feedback for one's future treatment.

Methodology

Description

There are four main parts in our newly developed template (Figure 1).

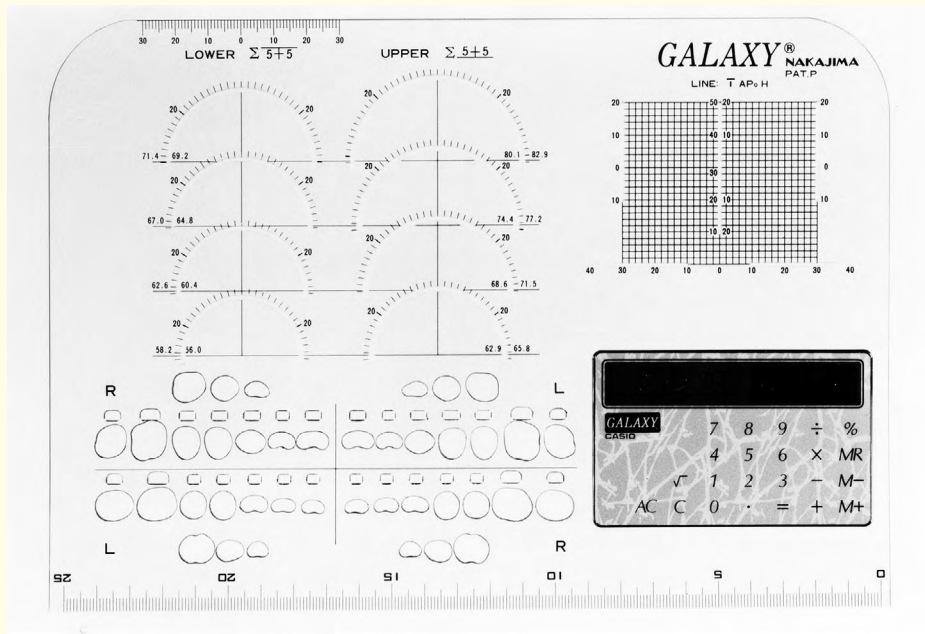

Figure 1: Nakajima template overview.

- 1) The Semicircle Outline : the operator can use this for a very wide range from -2.0SD to +1.5SD of Σ lower:5+5 or Σ upper:5+5 (mesio-distal width). One does not have to calculate the sum of the widths of lower: 5+5 (Figure 2).

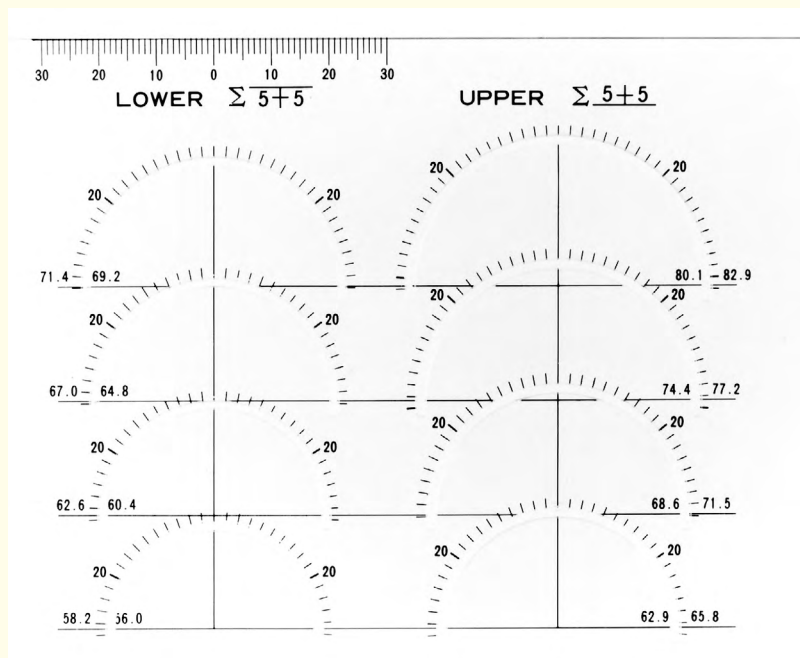

Figure 2: Semicircle outline.

- 2) The cross-sectional outline of the teeth and brackets.

The operator can get an actual image of the arch form for the treatment (Figure 3).

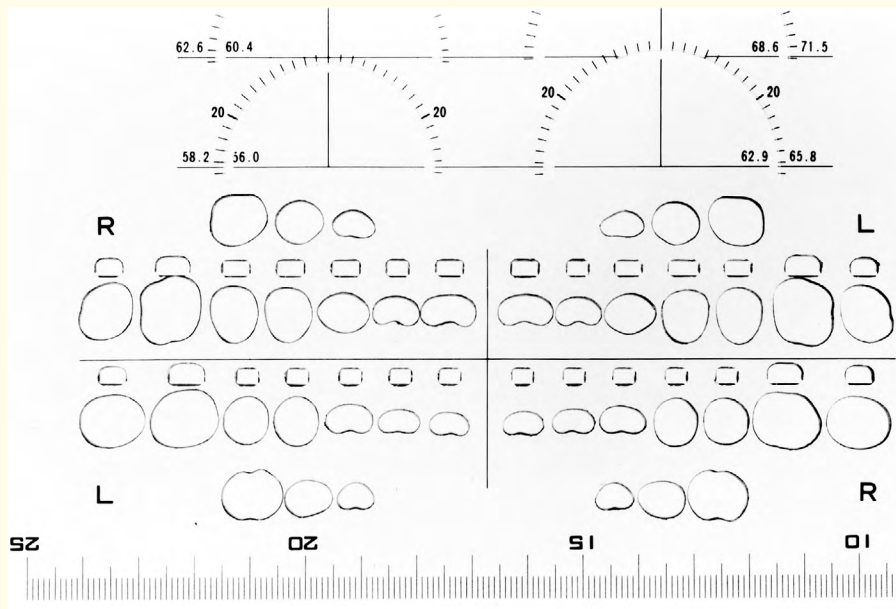

Figure 3: Cross-sectional outline of the teeth and brackets.

- 3) *L1 to APO H (lower incisor to APO Horizontal) indicator: One can readily locate and draw the midline as well as draw the L1 to APO-H line (Figure 4).

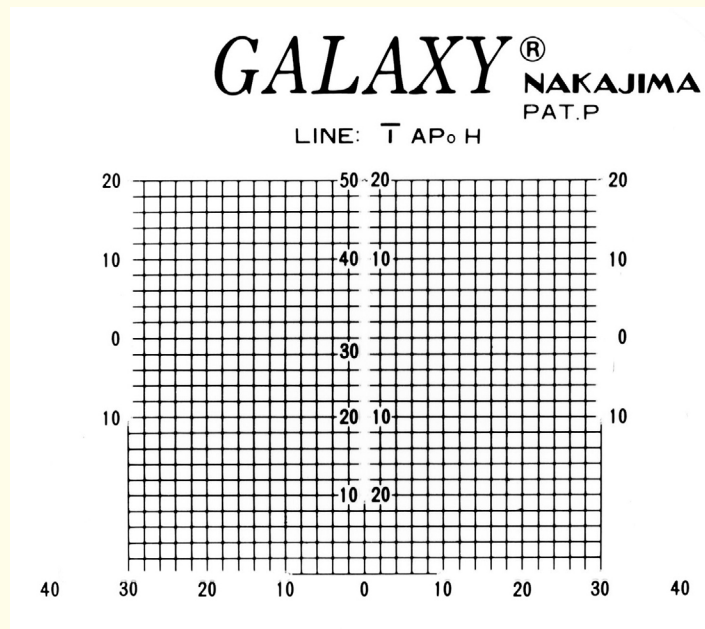

Figure 4: L1 to APO-H indicator.

- 4) Built-in calculator: the operator does not have to go looking for the calculator any longer (Figure 5).

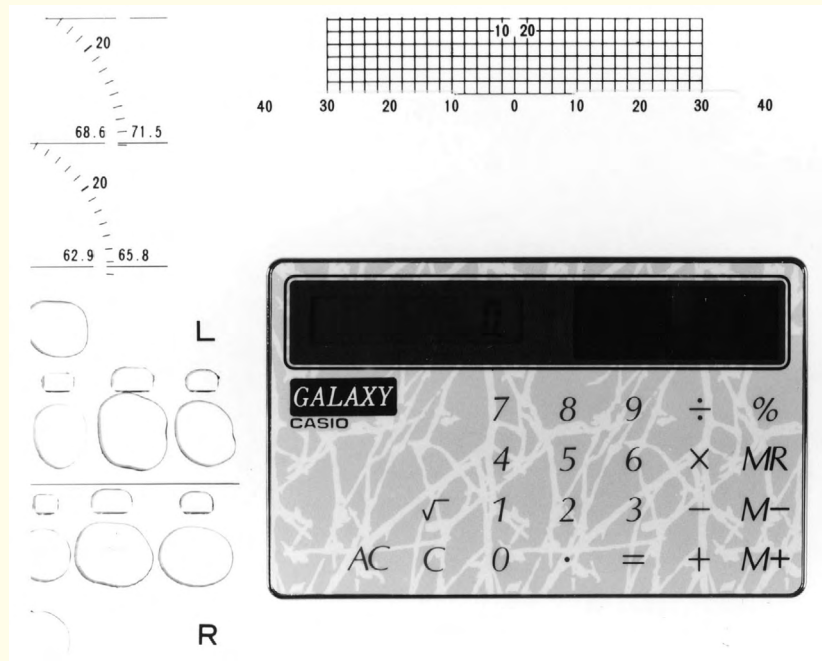

Figure 5: Built-in calculator.

*A line through APO line of a lateral tracing on a horizontal flat plane. The APO-H line is perpendicular to midline of a lower arch.

Results

Clinical Example

Clinical Summary

- M.N. 10Y female Class I Overjet 3.5 mm, Overbite 2.5 mm
- 10 Factor Analysis Before Treatment
- T1 tracing and 10 factor analysis
- VTO
- 5 super imposition

Diagnosis

- Extraction upper: 4/4 lower: E/E , Bioprogressive therapy

How to draw the lower arch VTO?

- 1) Cut the study model 1/3 distance from the occlusal surface with a trimmer. If it has a severe curve of spee or crowding, you can use a stump bur.
- 2) Draw outlines of each reduced teeth and mark contact points to the mesial and distal (Figure 6).

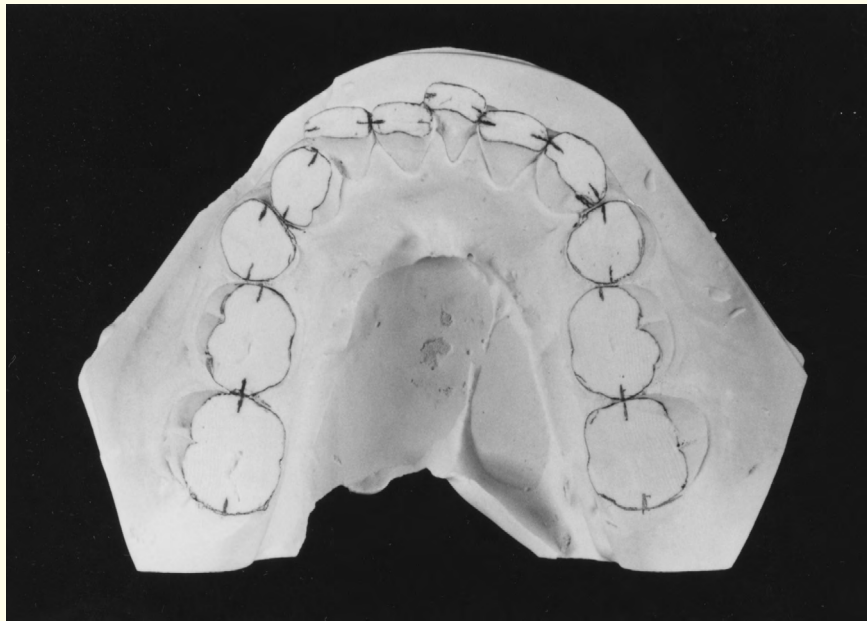

Figure 6: Draw outlines of each teeth.

3) Measure the bucco-lingual width (Figure 7).



Figure 7: Measure the bucco-lingual width.

- 4) Add the premeasured mesio-distal widths of lower: 5/5 from the work sheet (extraction) using the calculator. In this case the total widths of lower: 5/5 is 69.6 mm (Figure 8).

Measurement of Tooth width

Upper : bucco-lingual width, Lower : mesio-distal width

5.8	3.7	3.6	2.4	1.6	1.6	1.6	1.4	2.4	3.6	3.8	5.1
10.8	7.6	7.5	7.9	7.6	9.0	8.6	7.2	7.6	7.4	7.7	10.9
6	5	4	3	2	1	1	2	3	4	5	6
6	5	4	3	2	1	1	2	3	4	5	6
5.1	4.7	4.5	2.9	1.0	1.0	1.0	1.0	3.0	4.4	4.1	4.7
12.4	7.7	7.7	7.6	6.4	5.6	5.6	6.4	7.2	7.5	7.9	11.5

(mm)

Figure 8: Add the premeasured mesio-distal width.

- 5) Draw a basic line A using the upper left section of this template (Figure 9).

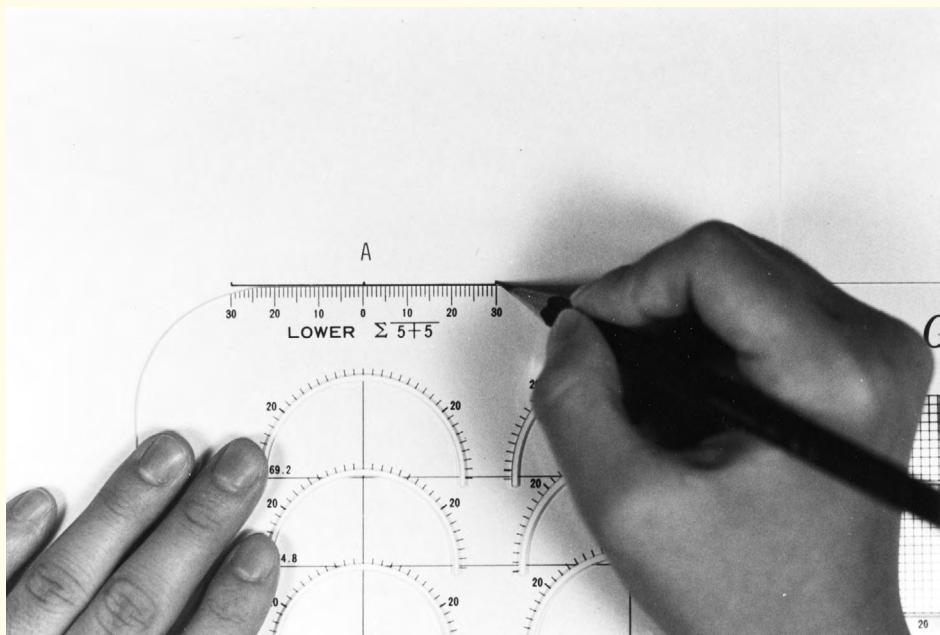

Figure 9: Draw a basic line A.

- 6) Then take a look at the semicircular section, and choose the closest number. Trace the upper part of the slit with a fine pencil. The radius is automatically calculated as 22.2 mm to this semicircle (Figure 10).

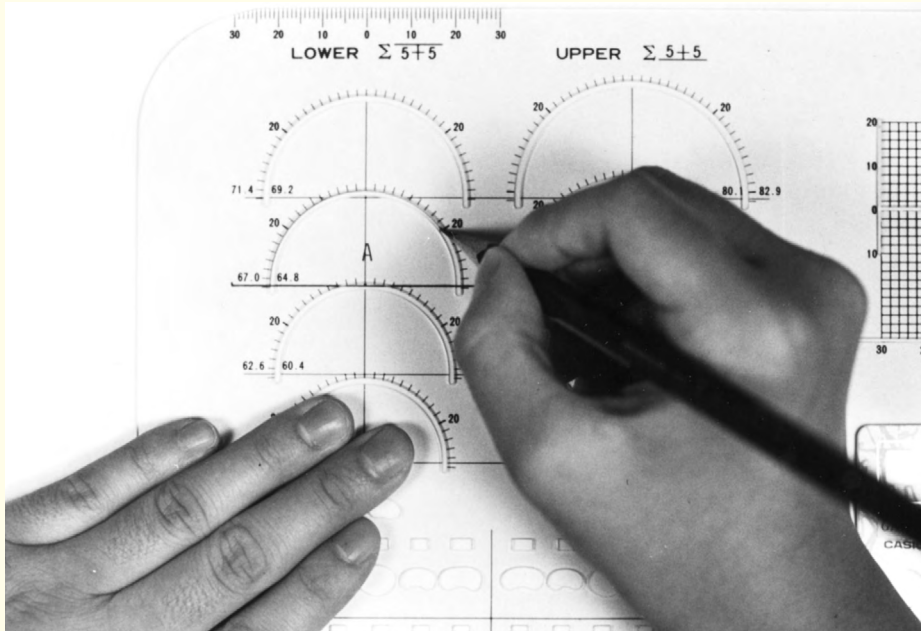

Figure 10: Choose the semicircular section.

- 7) Draw a semicircle with radius r from the bisected point O (Figure 11).

$$r = \frac{\Sigma_{\text{lower}5} - 5 \text{ (mesio-distal width)}}{i \cdot \pi}$$

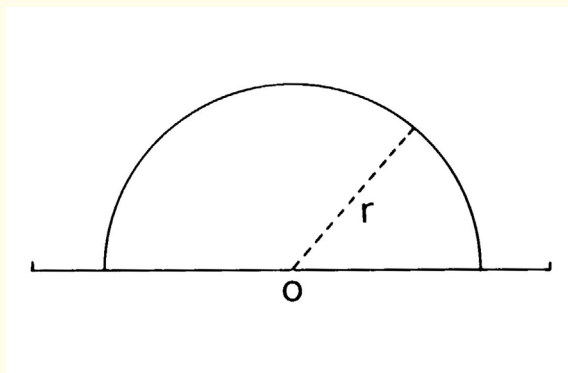

Figure 11: Draw a semicircle.

8) Please follow the instructions on the extraction case work sheet from this point (Table 1 and 2).

Lower Arch VTO (WORK SHEET)

Ext Case

CR Eiichiro Nakajima

Measurement of Tooth width

Upper: bucco-lingual width, Lower: mesio-distal width

6	5	4	3	2	1	1	2	3	4	5	6
6	5	4	3	2	1	1	2	3	4	5	6

(mm)

- 1 Draw a basic line A of 60mm.
- 2 Draw a semicircle width a radius r from a bisected point O.

$$r = \frac{\sum (5-5)}{\pi} \text{ (mesio-distal width)}$$

- 3 m = a intersection between a semicircle and a perpendicular line from O.
Mark width of central and lateral on a semicircle from the point m to both sides.
The distal contact points of left and right laterals are 2L and 2R.
- 4 Intersections between a semicircle and a basic line are 0L and 0R.
Bisect 2L-0L and 2R-0R.
nL and nR are bisected points.
- 5 Extend nL-0 and mark rR with 5r distance from O.
0-rR = 5r
Similarly draw the left side.
- 6 Extend nL-0 and mark r'R with 3r distance from O.
0-r'R = 3r
Similarly draw the left side.
- 7 Draw an arc from rR with a radius 2L-rR from 2L to the distal.
Mark widths of cuspid, and 2nd bicuspid or 1st bicuspid from 2L to the distal.
They are 3L, 5L or 4L.
Similarly draw the left side.
- 8 Draw a circle from r'R with a radius 5L-r'R from 5L to distally.
Mark width of a first molar from 5L.
This is 6L.
Similarly draw the left side.
This is the line of contact points.
- 9 Trace each tooth outline on a Line of contact points.
This is the individual arch form.
- 10 Draw a perpendicular line from a bisected point of each tooth.
Mark 0.6mm point on that line from the buccal surface.
- 11 Connect and draw these points with a smooth line. This is the individual lower arch wire form.

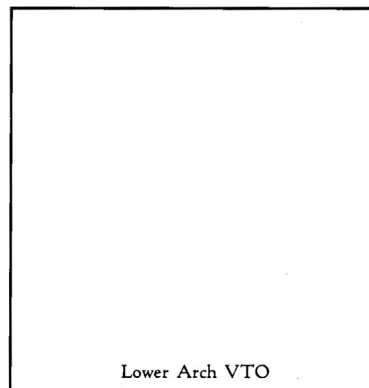

Table 1: The extraction case worksheet.

Lower Arch VTO (WORK SHEET)
NON Ext Case

CR Eiichiro Nakajima

Measurement of Tooth width

Upper: bucco-lingual width, Lower: mesio-distal width

6	5	4	3	2	1	1	2	3	4	5	6
6	5	4	3	2	1	1	2	3	4	5	6

(mm)

- 1 Draw a basic line A of 60mm.
- 2 Draw a semicircle width a radius r from a bisected point O.

$$r = \frac{\sum (5-5)}{\pi} \text{ (mesio-distal width)}$$

- 3 m = a intersection between a semicircle and a perpendicular line from O.
Mark width of central, lateral and cuspid on a semicircle from point m to both sides.
The distal contact point of left and right cuspids are 3L and 3R.
- 4 Intersections between the semicircle and the basic line are 0L and 0R.
Bisect 3L-0L and 3R-0R.
nL and nR are bisected points.
- 5 Extend nL-0 and mark rR with 2r distance from O.
0-rR = 2r
Extend nR-0 and mark rL with 2r distance from O.
0-rL = 2r
- 6 Draw a circle centered on rL with a 3R-rR radius from 3R to the distal.
Similarly the left side.
- 7 Mark mesio- distal widths of first bicuspid, second bicuspid and first molar from 3L to the distal.
These are 4L, 5L, 6L.
Similarly the right side.
This is the line of contact points.
- 8 Trace each tooth outline on the Line of contact points.
This is the individual arch form.
- 9 Draw a perpendicular line from a bisected point of each tooth.
Mark 0.6mm point on that line from the buccal surface.
- 10 Connect and draw these points with a smooth line. This is the individual lower arch wire form.

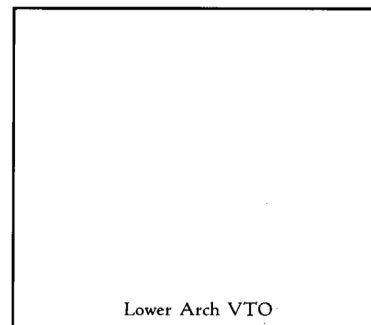

Table 2: For reference the non-extraction worksheet has been included.

- 9) This is a line of contact points.
- 10) Now trace each tooth outline forming a line of contact points using the cross sectional outline of the teeth and brackets in the template. This is the resulting Individual Arch Form.
- 11) Trace brackets and tubes using this template (Figure 12).

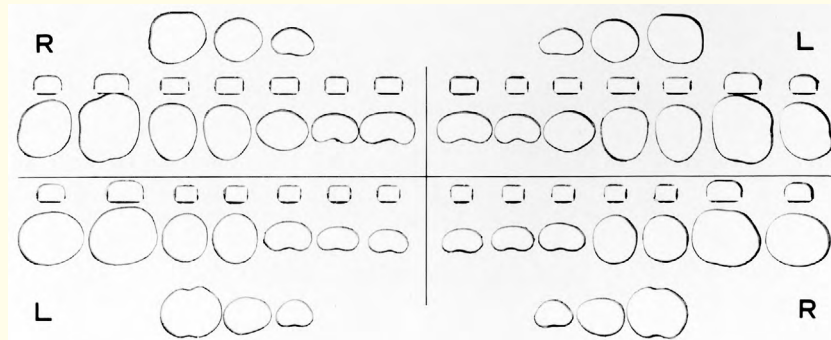

Figure 12: Trace brackets and tubes.

- 12) Connect and draw these bracket slots with a smooth line, again using the upper corner or the template. This is the individual lower arch wire form with brackets, tubes and wire (Figure 13).

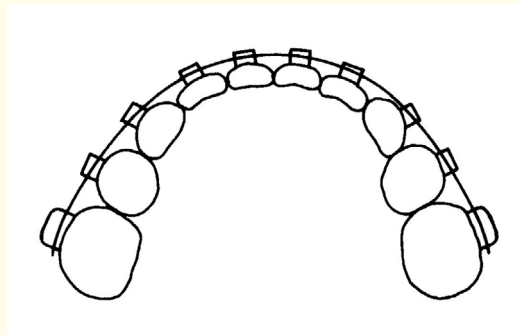

Figure 13: Individual lower arch wire form.

- 13) Draw a midline to this individual arch form and insert a L1 to *APO-V on this line from the lateral VTO. Then draw a perpendicular line through this point to the midline using the graph section of this template. This is the L1 to APO-H.
 *The point of the lateral APO line cut through the horizontal plane. You can transfer this point from the lateral tracing, as well as the distance between the APO line to the incisor of the lateral tracing. Draw the midline and the L1 to APO-H to the T1-lower arch.

Superimposition

- **Superimposition #1:** Superimpose T1-Lower Arch and an individual Lower Arch on the midline and the L1 to APO-H plane (Figure 14). Here we can see the mesio-distal, bucco-lingual, and the rotational movement of each tooth on the L1 to APO-H. The superimposition of the individual lower arch to the T2 lower arch is also shown. (Figure 15).

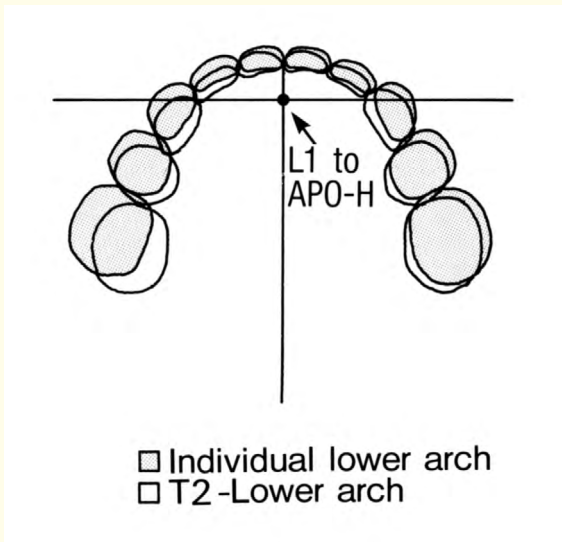

Figure 14: Draw a midline and a L1 to APO-V.

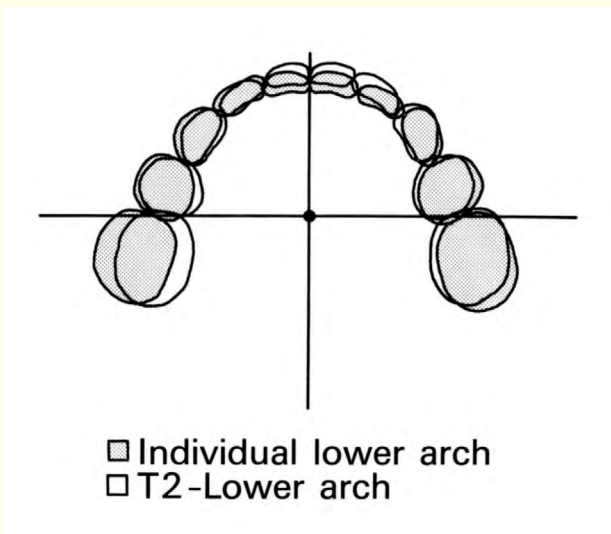

Figure 15: S#2 (Individual lower arch - T2 lower arch).

- **Superimposition #2:** Superimpose T1-Lower Arch and the Individual Lower Arch to the mesial contact point of both molars on a midline. We can see both the symmetrical relationship and differences in width. The superimposition of the individual lower arch to the T2 lower arch is also shown (Figure 16).

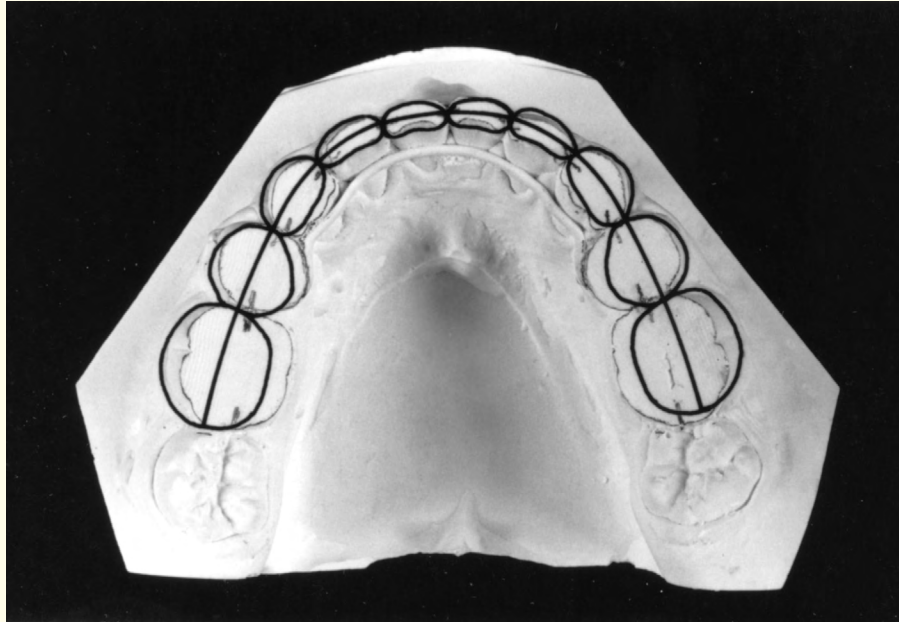

Figure 16: T2 Study model with the Individual arch form.

- **Superimposition #3:** Superimpose T1-Lower Arch and the Individual Lower Arch on the midline and *PTV-H. The width of AG-GA and JL-JR is also drawn on the PTV-H to check the maxillo-mandibular width. Superimposition #3 of the lateral tracing can be transferred here to visualize both the lateral and horizontal changes simultaneously. *Transfer the lateral PTV-molar distance to the horizontal diagram.
- **Superimposition #4:** Individual lower arch – T2 lower arch is also superimposed. This shows the T1 lower study model and the T2 lower study model with the individual arch form.

Discussion

The reasons for designing this template is very simple. We have not yet seen a template for a horizontal flat plane, although we observe them in every day practice as an arch form.

The advantages for using this template are as follows:

- 1) To actually visualize the treatment goal in the arch form at the onset of treatment.
- 2) To get an active working diagnosis in daily practice such as symmetry, asymmetry, width, protrusion and retrusion of the arch.
- 3) To obtain a more three dimensional data through transfers with lateral and frontal tracings.

The reasons for choosing a cut out model

There are many concepts regarding the “normal arch form” [1,2], but there are only a few clinical methods for determining the arch form and the arch length discrepancy [3,4]. The Bonwill Hawley arch used by Tweed and others was constructed by measuring through the contact points of a regular study model [2,5]. As Ricketts pointed out some confusing points to the method, they determined and measured the contact points through the cusps [2]. Often it is very difficult to locate the contact points and to measure their mesio-distal and buccolingual width in the regular T1 model. Let’s take a simple question. Where do we align the teeth with brackets? We want to align

the teeth at the slot level of the bracket. If we could cut out a tooth at the slot level, this cut out line passes through the contact points very closely. Therefore, we decided to use the cut out model instead of the regular study model, the occlusal photos or the model copies for taking measurements.

The reasons for choosing a cut out model

There are many concepts regarding the “normal arch form” [1,2], but there are only a few clinical methods for determining the arch form and the arch length discrepancy [3,4]. The Bonwill Hawley arch used by Tweed and others was constructed by measuring through the contact points of a regular study model [2,5]. As Ricketts pointed out some confusing points to the method, they determined and measured the contact points through the cusps [2]. Often it is very difficult to locate the contact points and to measure their mesio-distal and buccolingual width in the regular T1 model. Let’s take a simple question. Where do we align the teeth with brackets? We want to align the teeth at the slot level of the bracket. If we could cut out a tooth at the slot level, this cut out line passes through the contact points very closely. Therefore, we decided to use the cut out model instead of the regular study model, the occlusal photos or the model copies for taking measurements.

The Radius of the Semicircle

When we consider the arch form, there are some significant differences between taking the outer arch form and taking the line of contact points. If we take the outside(buccal) arch form, we need to consider toothsize, tooth form, torque, and inclination. These factors make the determination of the arch form very complicated. On the other hand, if we start the arch form using the line of contact points, the radius of the semicircle of the four incisors is only different from the sum of the four incisors mesio-distal width. Seventy percent of my patients at my clinic adapt to this curve.

The operator can then add the actual bucco-lingual width to this curve. In addition, this formula is very close to Ricketts’s Normal form [2].

Other applications

- 1) **Horizontal and Sagittal:** If you add the sagittal tooth form transferred from the lateral tracing to this horizontal flat plane, you can readily visualize the horizontal and the sagittal relationships on the same plane.
- 2) **Horizontal, Sagittal and Frontal:** If you add the widths of, JL-JR, AG-GA, you can readily visualize the three dimensional relationships on the same plane. These relationships are a case for future research regarding this template.
- 3) **Pre-formed arch wire:** The operator can make arch wires of both the initial and the final steps using this template. We have already produced the prototype initial wire made from a so called memorial alloyed wire to this arch form.
- 4) **Teaching:** I think this template can be especially beneficial in teaching the orthodontic student how to recognize arch management in three dimensions.
- 5) **Upper arch form:** The operator can also apply this template to the upper arch. The procedure is the same as in the lower arch. Only the superimposition areas are different from the lower arch.
 - a. Superimposition #1: Superimpose at the *point A-H on the Lower Midline.
 - b. Superimposition #2: Superimpose at the mesial contact points of both molars on the midline.
 - c. Superimposition #3: Superimpose on the midline and the PTV-H.

*Point A-H: Transfer the distance between point A to APO line of the lateral tracing to this horizontal Plane.
- 6) **Room for improvement:** You can make other templates for use in ovoid, tapered or other type arches, if you could find critical reasons for applying such arch forms to the individual case.

Conclusion

I believe that every clinician can use this template in their daily clinic as a very useful tool not only for diagnoses and a consultation but also for daily clinical treatment.

Bibliography

1. Ricketts RM. "A Detailed Consideration of the Line of Occlusion". *Angle Orthodontist* 48.4 (1978): 274-282.
2. Ricketts RM. "Research in Factors of Appliance Designed and Arch Form". Foundation For Orthodontic Research (1979): 47-49.
3. Dale JG. "Chapter 5 (Orthodontics current principles and techniques: Graber TM)". *Guidance of occlusion: serial extraction* (1985): 299-303.
4. Tweed CH. "The Frankfort mandibular incisor angle(FMIA) in orthodontic diagnosis, treatment planning and prognosis". *Angle Orthodontist* 24.3 (1954): 124-169.
5. Musich DR and Ackeman JL. "The cateno-meter: A reliable device for estimating dental arch perimeter". *American Journal of Orthodontics* 63.4 (1973): 366-375.

Volume 17 Issue 5 May 2018

©All rights reserved by Eiichiro Nakajima., *et al.*